

# D2xC1X05 Alarm Horn Sounder & Xenon Strobe Beacon

The D2xC1X05 features a high output, 116dB(A) alarm horn sounder combined with a 5 Joule Xenon strobe beacon.

One device, globally certified: ATEX, IECEx Zone 2 & 22; NEC/CEC CI D2 and CII D2; NEC CI Zone 2 and Zone 22; CEC Zone 2 & 22 and CII D2.

Low current consumption and high SPL in a robust Type 4/4X, IP66 enclosure ensure the D2xC1X05 is suitable for all haz loc general signalling applications including fire, security and process control. The corrosion proof, marine grade aluminium die cast enclosure is phosphated and powder coated providing resilience in the harshest of hazardous location environments.

## Features

- 5 Joule Xenon beacon
- High output, up to 116dB(A)
- 4 remotely selectable alarm stages/channels
- Positive or negative line stage/channel switching (DC units)
- Choice of 64 alarm tone frequencies
- Automatic synchronisation on multi-sounder system
- Continuously rated
- Compact form factor
- Robust corrosion proof aluminium enclosure
- Stainless steel fixings
- Dual cable entries
- Duplicate cable terminations (in & out for daisy-chain installations)
- Available with custom tone configurations and frequencies
- Field changeable lens colours

## Approvals

- UL File ref: E230764  
ANSI/ISA 12.12.01 - 2013,  
CSA C22.2 No. 213-M1987  
Standards:  
ANSI/UL60079-0-13,  
ANSI/UL60079-15-2013,  
ISA60079-31-2009  
CAN/CSA C22.2 No. 60079-0-11,  
CAN/CSA C22.2 No. 60079-15-12,  
CAN/CSA C22.2 No. 60079-31-12
- IECEx certificate: IECEx ULD 14.0004X  
Standards:  
IEC60079-0: ed. 6.0 (2011-06),  
IEC60079-15: ed. 4.0 (2010-01),  
IEC60031-31: ed. 2.0 (2013-11)
- ATEX certificate: DEMKO 14 ATEX 1338779X  
Standards:  
EN60079-0:2012,  
EN60079-15:2010,  
EN60079-31:2009



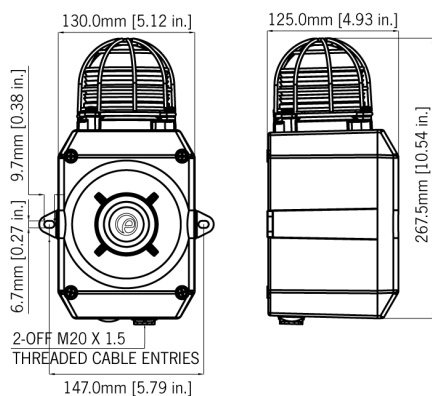

## Specification

### Horn Sounder:

Maximum output:	116dB(A) @ 1 metre [107dB(A) @ 10ft/3m]
Nominal output:	112dB(A) @ 1m +/- 3dB - Tone 2 [103dB(A) @ 10ft/3m]
No. of tones:	64 (UKOOA / PFEER compliant)
No. of stages:	4
Volume control:	Adjustable -12dB(A) [Tone 2]
Effective range:	125m/410ft @ 1KHz
Stage switching:	DC units - Positive or Negative line. AC units - common supply line

### Strobe Beacon:

Energy:	5 Joules (5Ws)
Flash rate:	1Hz (60 fpm)
Peak Candela:	500,000 cd - calculated from energy (J)
Effective Intensity cd:	250 cd - calculated from energy (J)
Peak Candela:	33,410 cd - measured ref. to I.E.S.
Effective Intensity:	94.78 cd - measured ref. to I.E.S.
Lens colours:	Amber, Blue, Clear, Green, Magenta, Red & Yellow
Tube life:	Emissions are reduced to 70% after 8 million flashes

### General:

Voltages DC:	24V dc [20-28Vdc]; 48V dc [38-58Vdc]
Voltages AC:	115V ac 50/60Hz; 230V ac 50/60Hz
Ingress protection:	EN60529: IP66 UL50E / NEMA250: 4 / 4X / 3R / 13
Housing material:	Marine grade aluminium Al Si12 Cu
Colour:	Red (RAL3000), grey (RAL7038)
Cable entries:	2 x M20 x 1.5mm threaded gland entries
Terminals:	0.5 - 2.5mm <sup>2</sup> (20-14 AWG)
Grounding stud:	M5
Operating temp:	-40 to +70°C [-40° to +158°F] - Class I Div 2 -40 to +50°C [-40° to +122°F] - All other approvals
Relative humidity:	90% at 20°C [68°F]
Weight:	DC: 2.80kg/6.16lbs AC:3.10kg/6.82lbs

## Part Codes

Version:	Part code:
24V dc	D2xC1X05DC02 4A1 [x]/[y]
48V dc	D2xC1X05DC048A1 [x]/[y]
115V ac	D2xC1X05AC115A1 [x]/[y]
230V ac	D2xC1X05AC230A1 [x]/[y]
[x] =	G: Grey, R: Red [Enclosure colours]
[y] =	A: Amber, B: Blue, C: Clear, G: Green, M: Magenta, R: Red, Y: Yellow [Lens colours]

## Ratings:

NEC / CEC:	Class I Div 2 ABCD T2B Ta -40°C to +70°C
	Class I Div 2 ABCD T2C Ta -40°C to +55°C
	Class I Div 2 ABCD T2D Ta -40°C to +40°C
	Class II Div 2 FG T5 Ta -40°C to +50°C
	Class III Div 1&2 Ta -40°C to +50°C
NEC:	Class I Zone 2 AEx nA IIC T2 Gc (Ta -40°C to +50°C)
	Zone 22 AEx tc IIIC 120°C Dc (Ta -40°C to +50°C)
CEC:	Class I Zone 2 Ex nA IIC T2B Gc X (Ta -40°C to +50°C)
	Class I Zone 2 Ex nA IIC T2C Gc X (Ta -40°C to +45°C)
	Zone 22 Ex tc IIIC 120°C Dc (Ta -40°C to +50°C)
	Class II Div 2 EFG T4A Ta -40°C to +50°C
IECEX & ATEX	II 3G Ex nA IIC T2 Gc (Ta -40°C to +50°C)
	II 3D Ex tc IIIC 90°C Dc (Ta -40°C to +50°C)

## Alarm Sounder

Version:	Voltage:	Current:
24V dc	10-30V dc	313mA [at nominal voltage]
48V dc	38-58V dc	181mA [at nominal voltage]
115V ac	50/60Hz +/-10%	90mA
230V ac	50/60Hz +/-10%	52mA

## Xenon Beacon

Version:	Voltage:	Current:
24V dc	20-28V dc	250mA [at nominal voltage]
48V dc	42-54V dc	149mA [at nominal voltage]
115V ac	50/60Hz +/-10%	70mA
230V ac	50/60Hz +/-10%	35mA

## Tone table

S 1	Description	S 2	S 3	S 4	S 1	Description	S 2	S 3	S 4
T 1	1000 Continuous - PFEER Toxic Gas	T 3	T 2	T 44	T 33	800 (0.25s on, 1.00s off) Intermittent	T 53	T 24	T 8
T 2	1200/500 @ 1Hz Sweeping - DIN / PFEER P.T.A.P.	T 1	T 3	T 44	T 34	800 @ 2Hz (0.25s on, 0.25s off) - IMO code 3...	T 56	T 24	T 8
T 3	1000 @ 0.5Hz (1s on, 1s off) Intermittent - P...	T 1	T 2	T 44	T 35	1000 @ 1Hz (0.50s on, 0.50s off) Intermittent	T 44	T 24	T 8
T 4	1.4KH-1.6KHz 1s, 1.6KHz-1.4KHz 0.5s - NF C 48...	T 44	T 24	T 1	T 36	2400 @ 1Hz (0.50s on, 0.50s off) Intermittent	T 21	T 24	T 8
T 5	544(100mS)/440 (400mS) - NF S 32-001	T 52	T 19	T 1	T 37	2900 @ 5Hz (0.10s on, 0.10s off) Intermittent	T 53	T 24	T 8
T 6	1500/500 - (0.5s on , 0.5s off) x3 + 1s gap -...	T 7	T 44	T 1	T 38	363/518 @ 1Hz (0.50s / 0.50s) Alternating	T 1	T 8	T 19
T 7	500-1500Hz Sweeping 2 sec on 1 sec off - AS4428	T 6	T 44	T 1	T 39	450/500 @ 2Hz (0.25s / 0.25s) Alternating	T 1	T 8	T 19
T 8	500/1200Hz @ 0.26Hz(3.3s on, 0.5s off) - NEN ...	T 44	T 24	T 35	T 40	554/440 @ 1Hz (0.50s / 0.50s) Alternating	T 44	T 24	T 19
T 9	1000 (1s on, 1s off)x7 + (7s on, 1s off) - IM...	T 18	T 34	T 1	T 41	554/440 @ 0.65Hz (0.76s / 0.76s) Alternating	T 1	T 8	T 19
T 10	1000 (1s on, 1s off)x7 + (7s on, 1s off) - IM...	T 21	T 34	T 1	T 42	561/760 @ 0.83Hz (0.60s / 0.60s) Alternating	T 1	T 8	T 19
T 11	420(0.5s on, 0.5s off)x3 + 1s gap - ISO 8201 ...	T 44	T 1	T 8	T 43	780/600 @ 0.96Hz (0.52s / 0.52s) Alternating	T 1	T 8	T 19
T 12	1000(0.5s on, 0.5s off)x3 + 1s gap - ISO 8201...	T 44	T 1	T 8	T 44	800/1000 @ 2Hz (0.25s / 0.25s) Alternating	T 5	T 24	T 19
T 13	422/775 - (0.85 on, 0.5 off) x3 + 1s gap - ...	T 44	T 1	T 8	T 45	970/800 @ 2Hz (0.25s / 0.25s) Alternating	T 1	T 8	T 19
T 14	1000/2000 @ 1Hz - Singapore	T 23	T 3	T 35	T 46	800/1000 @ 0.875Hz (0.57s / 0.57s) Alternating	T 53	T 24	T 19
T 15	300 Continuous	T 44	T 24	T 35	T 47	2400/2900 @ 2Hz (0.25s / 0.25s) Alternating	T 57	T 24	T 19
T 16	440 Continuous	T 44	T 24	T 35	T 48	500/1200 @ 0.3Hz (1.67s / 1.67s) Sweeping	T 44	T 24	T 12
T 17	470 Continuous	T 44	T 24	T 35	T 49	560/1055 @ 0.18Hz (2.73s / 2.73s) Sweeping	T 44	T 24	T 12
T 18	500 Continuous - IMO code 2 (Low)	T 44	T 24	T 35	T 50	560/1055 @ 3.3Hz (0.15s / 0.15s) Sweeping	T 44	T 24	T 12
T 19	554 Continuous	T 64	T 24	T 35	T 51	600/1250 @ 0.125Hz (4s / 4s) Sweeping	T 44	T 24	T 12
T 20	660 Continuous	T 44	T 24	T 35	T 52	660/1200 @ 1Hz (0.50s / 0.50s) Sweeping	T 64	T 24	T 12
T 21	800 Continuous - IMO code 2 (High)	T 44	T 24	T 35	T 53	800/1000 @ 1Hz (0.50s / 0.50s) Sweeping	T 56	T 24	T 12
T 22	1200 Continuous	T 44	T 24	T 35	T 54	800/1000 @ 7Hz (0.07s / 0.07s) Sweeping	T 57	T 24	T 12
T 23	2000 Continuous	T 15	T 3	T 35	T 55	800/1000 @ 50Hz (0.01s / 0.01s) Sweeping	T 54	T 24	T 12
T 24	2400 Continuous	T 48	T 20	T 35	T 56	2400/2900 @ 7Hz (0.07s / 0.07s) Sweeping	T 57	T 24	T 12
T 25	440 @ 0.83Hz (0.60s on, 0.60s off) Intermittent	T 1	T 44	T 8	T 57	2400/2900 @ 1Hz (0.50s / 0.50s) Sweeping	T 47	T 24	T 12
T 26	470 @ 0.9Hz (0.55s on, 0.55s off) Intermittent	T 1	T 44	T 8	T 58	2400/2900 @ 50Hz (0.01s / 0.01s) Sweeping	T 54	T 24	T 12
T 27	470 @ 5Hz (0.10s on, 0.10s off) Intermittent	T 1	T 44	T 8	T 59	2500/3000 @ 2Hz (0.25s / 0.25s) Sweeping	T 44	T 24	T 12
T 28	544 @ 1.14Hz (0.43s on, 0.44s off) Intermittent	T 44	T 24	T 8	T 60	2500/3000 @ 7.7Hz (0.65s / 0.65s) Sweeping	T 44	T 24	T 12
T 29	655 @ 0.875Hz (0.57s on, 0.57s off) Intermittent	T 1	T 44	T 8	T 61	800Hz Motor Siren	T 44	T 24	T 12
T 30	660 @ 0.28Hz (1.80s on, 1.80s off) Intermittent	T 44	T 24	T 8	T 62	1200Hz Motor Siren	T 44	T 24	T 12
T 31	660 @ 3.3Hz (0.15s on, 0.15s off) Intermittent	T 30	T 24	T 8	T 63	2400Hz Motor Siren	T 44	T 24	T 12
T 32	745 @ 1Hz (0.50s on, 0.50s off) Intermittent	T 44	T 24	T 8	T 64	Simulated Bell	T 44	T 21	T 12